

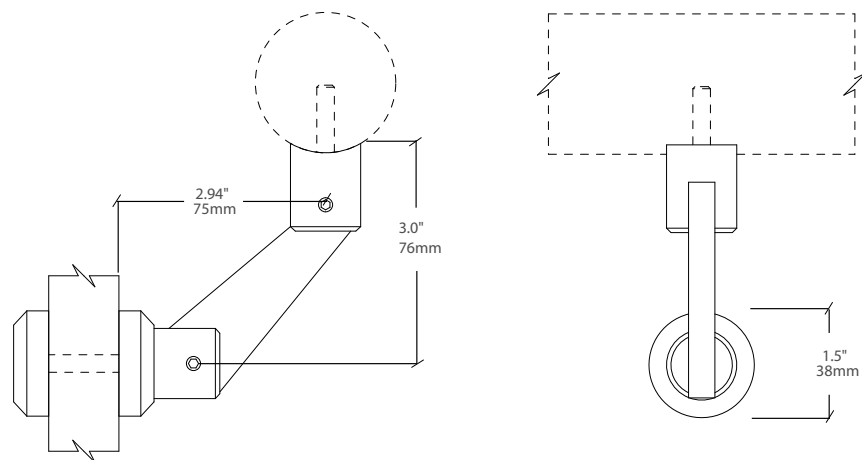

**MATERIAL:** ALL MACHINED ALLUMINUM COMPONENTS ARE 6061 ALUMINUM ALLOY.  
\* ALSO AVAILABLE IN STAINLESS STEEL, PLEASE INQUIRE.

**NOTE:** \* ALSO AVAILABLE FOR ATTACHMENT TO ROUND CONDITION SUPPORT STRUCTURE, PLEASE INQUIRE.  
\*\* WITH THROUGH HOLE, UNTAPPED (BY OTHERS)

**FINISH:** STANDARD FISNISH ON ALL MACHINED COMPONENTS IS SATIN ANODIZED.

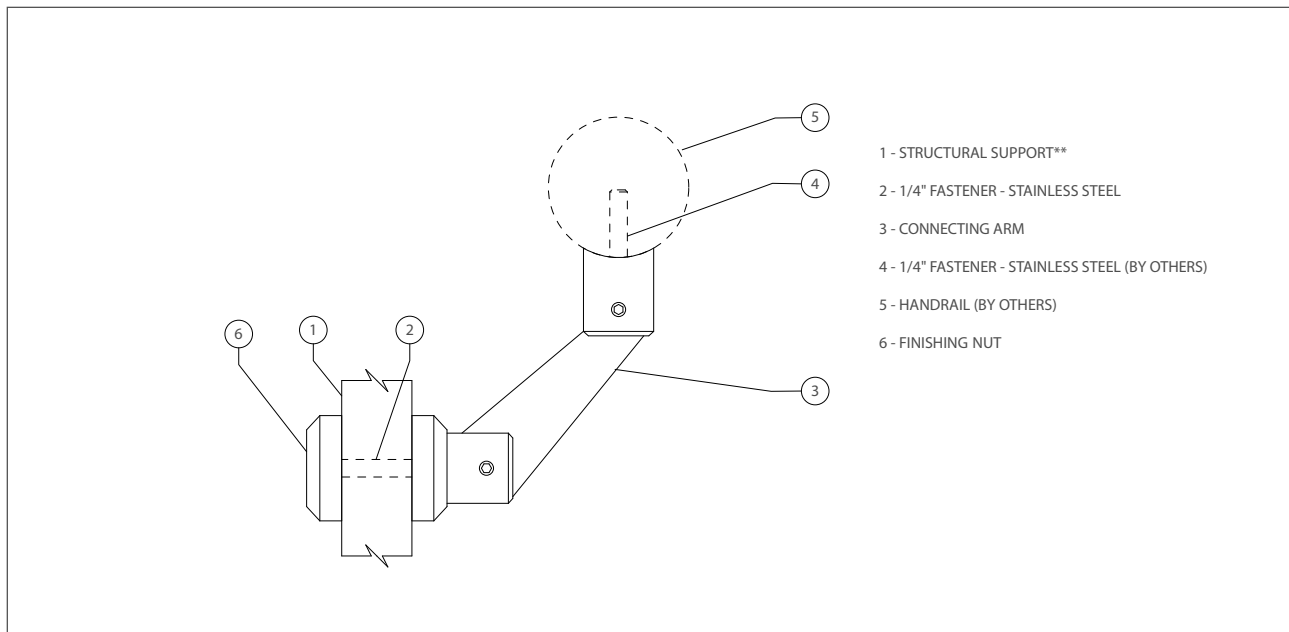

**LIMITATIONS:** Products supplied from our standard offering, modified and manufactured to submitted designs, project specific products, and products sourced and supplied by third parties should be approved by your own engineers for compliance and certification. Architectural Fittings are not certified engineers. It is the buyers responsibility to ensure that the application of all Architectural Fittings products is suitable for its intended use, and compliant with any relevant standards. Any liability of Architectural Fittings is limited to the replacement value of products supplied by us. Architectural Fittings reserves the right to alter product specifications without notice. Architectural Fittings products are protected by copyright and design registrations, all rights reserved.